

# BRUSHY CREEK STATE RECREATION AREA



[www.exploreiowaparks.com](http://www.exploreiowaparks.com)











IOWA STATE PARKS  
IOWA DEPARTMENT OF NATURAL RESOURCES

# BRUSHY CREEK STATE RECREATION AREA

(6,500 acres)

One of the largest state areas for outdoor fun, Brushy Creek allows visitors to get away from it all. With its 260-acre state preserve nestled in the middle of its boundaries, it is easy to find a beautiful view of Brushy Creek's Valley or surround yourself with the unique natural resources it has to offer. From fishing to hunting to trail riding, Brushy Creek is the perfect setting for any activity.

A great spot for avid equestrians, Brushy Creek offers horse friendly modern camping as well as two large day-use areas. Wander along miles of trails winding through Brushy Creek's natural beauty on foot, horseback, mountain bike, snow skis or snowmobile. Any way you decide to explore the park, you will have plenty of outdoor fun and adventures.

-  **Trails:** Hiking, mountain biking, equestrian, cross-country skiing, snowmobiling
-  **Fishing:** Stream or lake (690 ac.); fish-cleaning station; pier; jetties; bass, walleye, catfish, black crappie, bluegill, muskie
-  **Boating:** Boat ramps; any-size motor, no-wake speed
-  **Swimming:** Designated beach
-  **Picnicking/Shelters:** Picnic areas throughout the park; open shelters for reservation
-  **Camping:** 39 electric, 14 full hook-ups; modern rest rooms and showers; dump station; playground
-  **Equestrian Camping:** Two campgrounds, 109 electric, 97 non-electric; modern rest rooms and showers; dump stations; playground at north campground
-  **Hunting:** Hunting areas marked with green public hunting signs; target ranges nearby

## Nearby attractions:

### Fort Dodge:

- Blanden Memorial Art Museum
- Fort Museum & Frontier Village
- Frontier Days (June)
- Gypsum City OHV Park

### Dayton:

- Dayton National Championship Rodeo: carnival, flea market, parade (Labor Day weekend)

## RESERVATIONS

To reserve a campsite or shelter, visit [www.reserveiaparks.com](http://www.reserveiaparks.com) call 1-877-IAPARKS (427-2757)

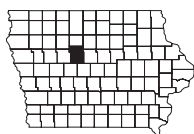

3175 290th Street  
Lehigh, Iowa 50557  
515.543.8298  
[Brushy\\_Creek@dnr.iowa.gov](mailto:Brushy_Creek@dnr.iowa.gov)

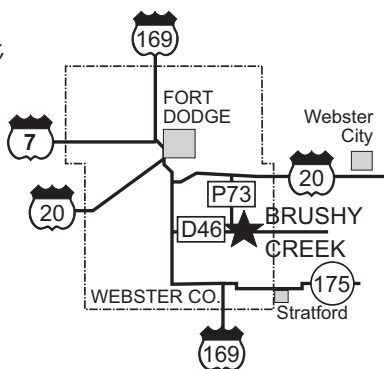

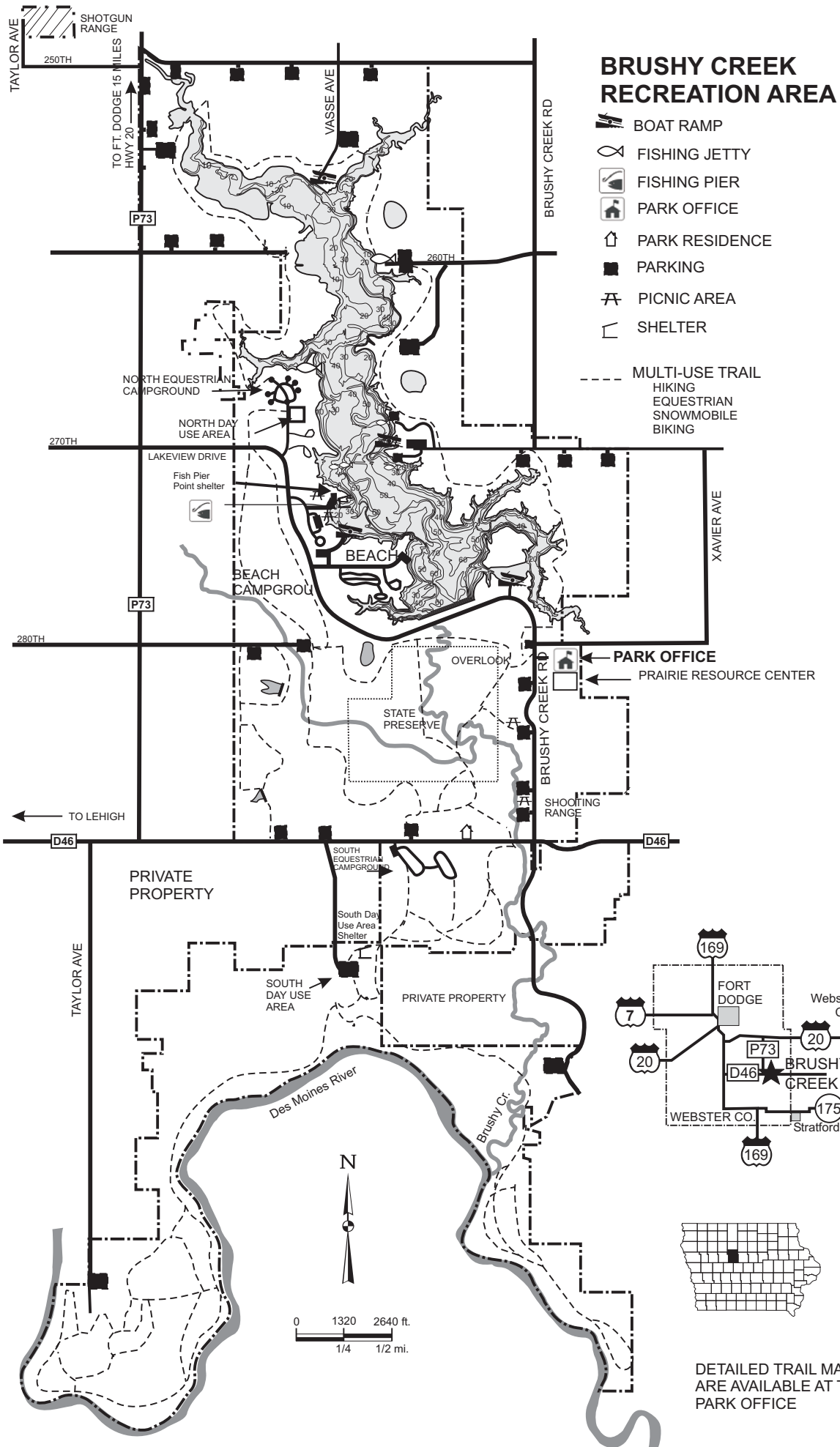

DETAILED TRAIL MAPS ARE AVAILABLE AT THE PARK OFFICE

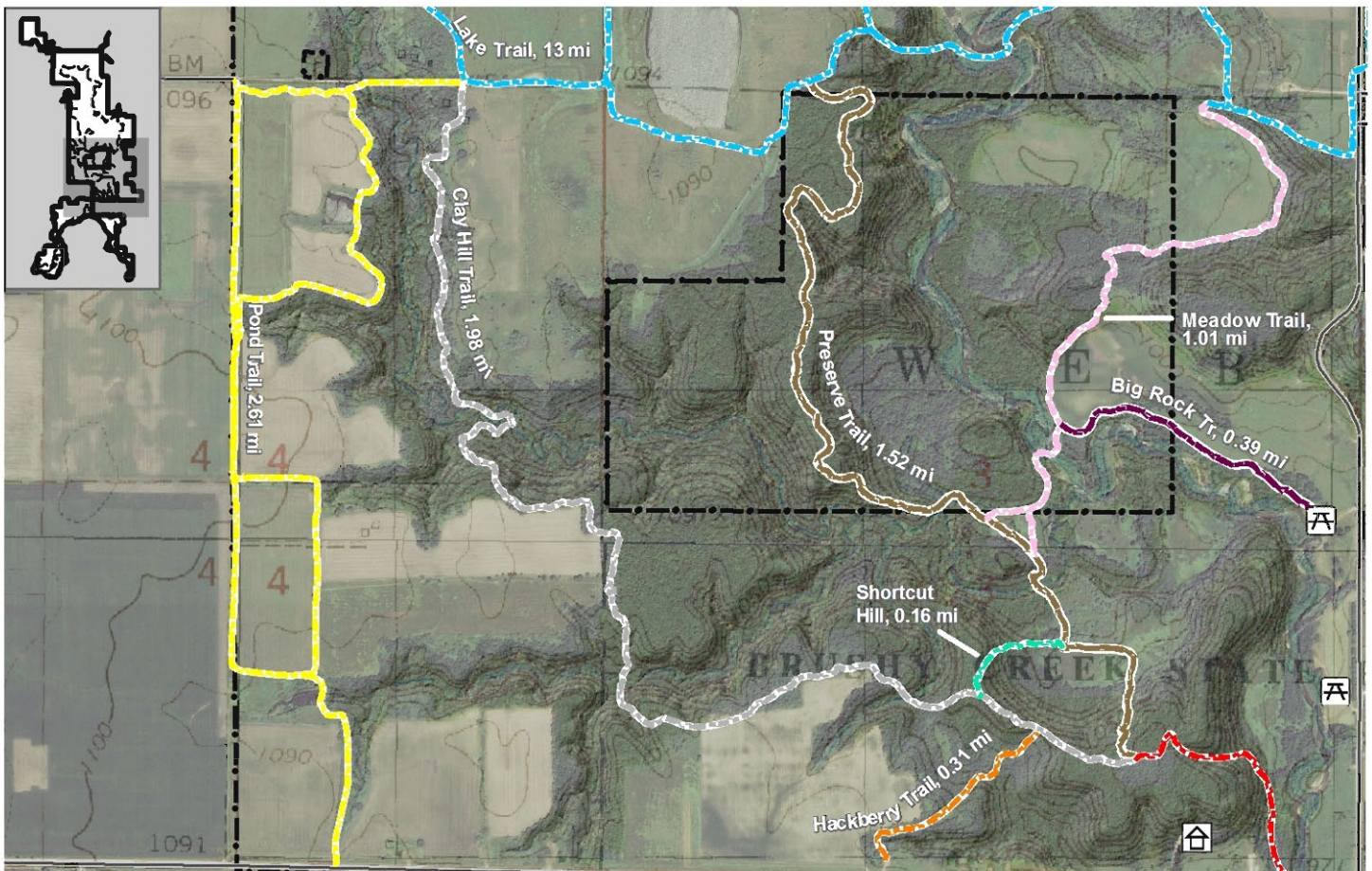

# BRUSHY CREEK STATE RECREATION AREA

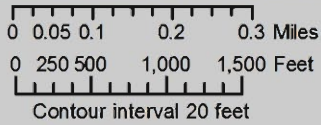

## Trails Map - Central



Multi-use Trails: Hiking, Mtn Biking  
X-C Skiing, Snowmobile, Equestrian

Trails open to foot traffic only during wet conditions. Call the park office for trail conditions. The Lake Trail is an all-weather rock trail that remains open.

Park Office: 515-543-8298  
Sheriff's Dept: 515-573-1410

- Campground
- Picnic Area
- Shelter
- Park Residence





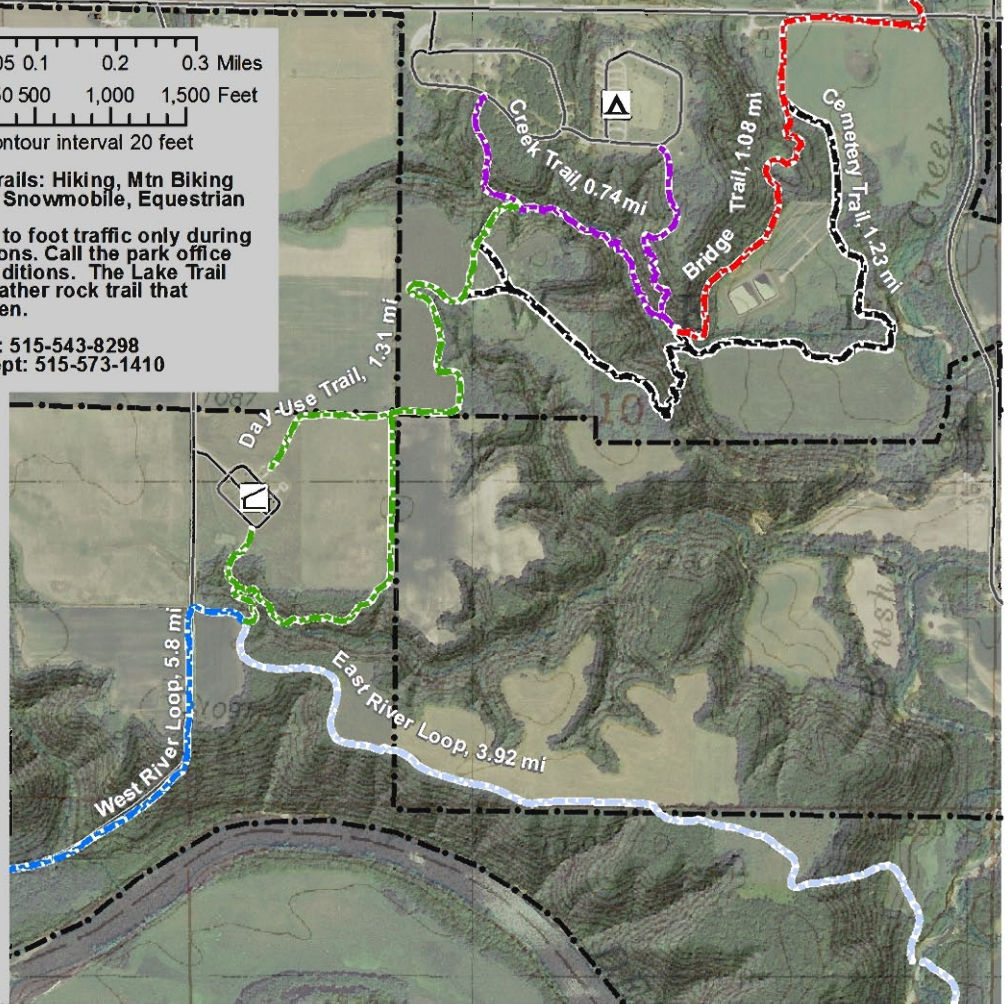







- Big Rock Trail, Multi Use
- Bridge Trail, Multi Use
- Cemetery Trail, Multi Use
- Clay Hill Trail, Multi Use
- Creek Trail, Multi Use
- Day Use Trail, Multi Use
- East River Loop, Multi Use
- Hackberry Trail, Multi Use
- Lake Trail, Multi Use
- Meadow Trail, Multi Use
- Pond Trail, Multi Use
- Preserve Trail, Multi Use
- Shortcut Hill, Multi Use
- West River Loop, Multi Use

- Roads
- Park Boundary

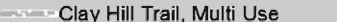

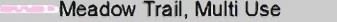
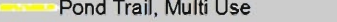
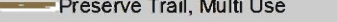
# BRUSHY CREEK STATE RECREATION AREA

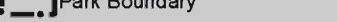
## Lake Trail

-  Boat Ramp
-  Campground
-  Park Office
-  Picnic Area
-  Pier
-  Shelter
-  Campground Trail, No Horses
-  Clay Hill Trail, Multi Use
-  Lake Trail, Multi Use
-  Meadow Trail, Multi Use
-  Pond Trail, Multi Use
-  Preserve Trail, Multi Use
-  Roads
-  Park Boundary



Multi-use Trails: Hiking, Mtn Biking, X-C Skiing, Snowmobile, Equestrian

Trails open to foot traffic only during wet conditions. Call the park office for trail conditions. The Lake Trail is an all-weather rock trail that remains open.

Park Office: 515-543-8298  
 Sheriff's Dept: 515-573-1410

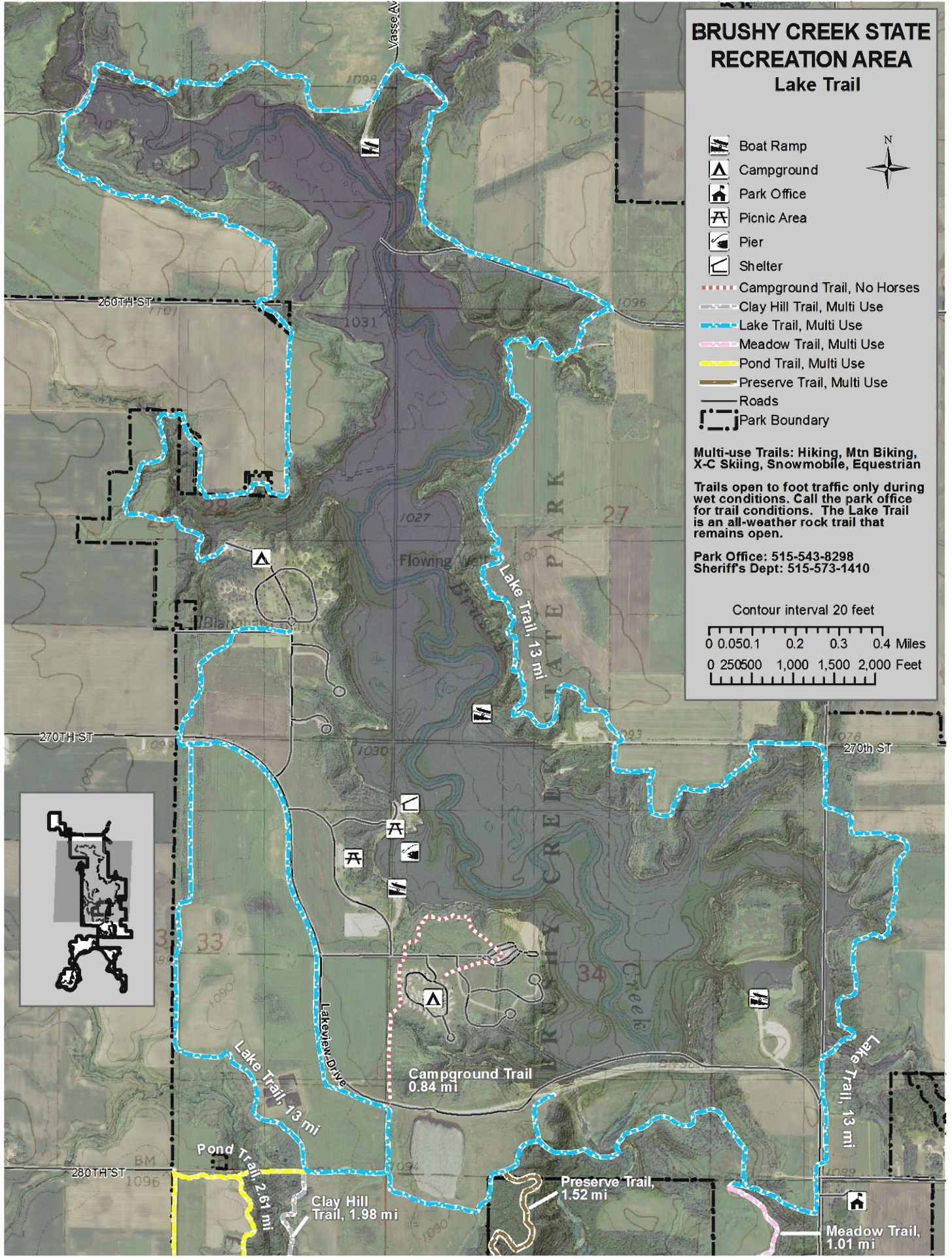
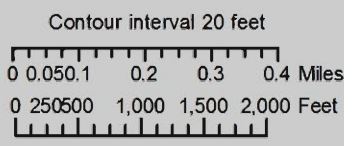

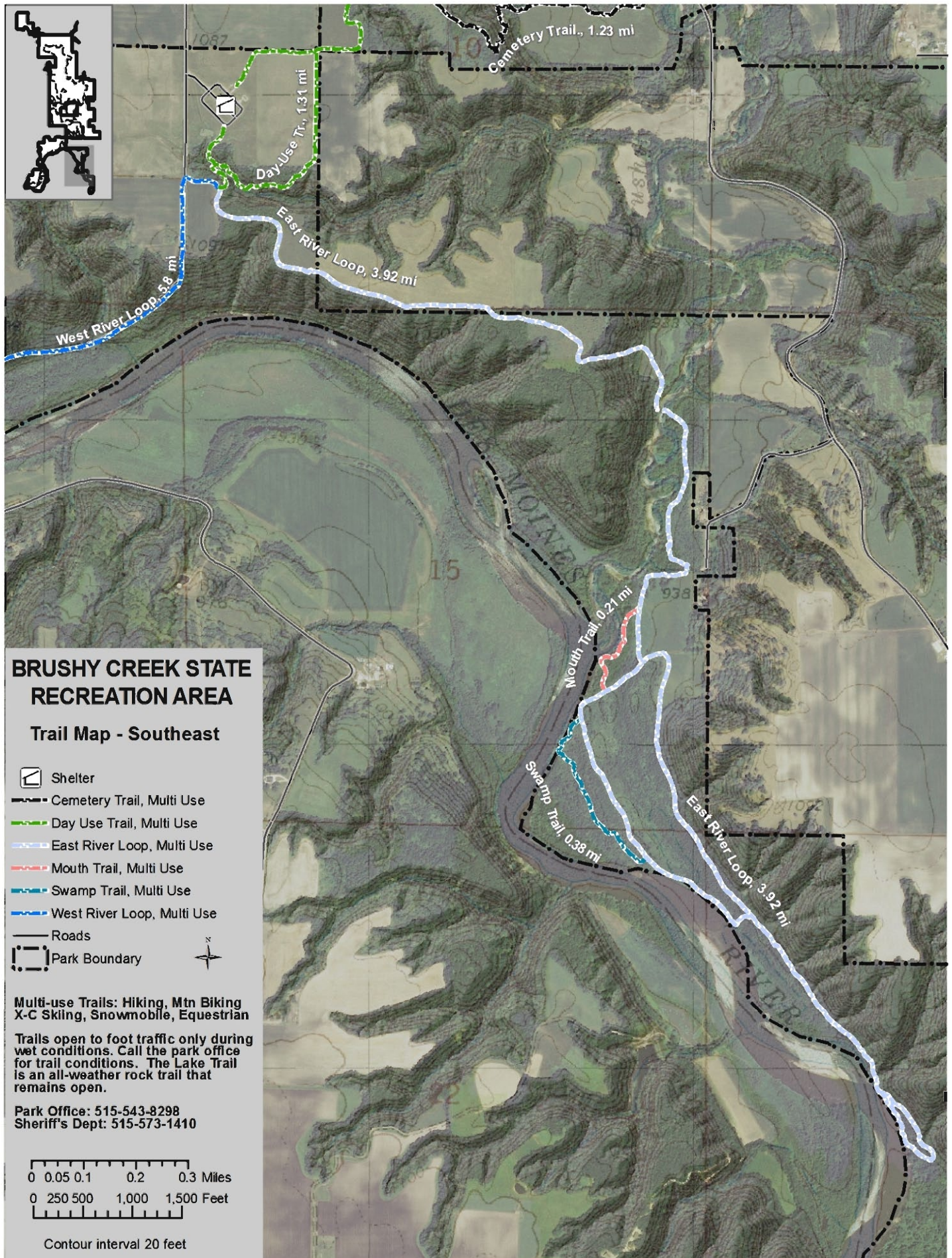
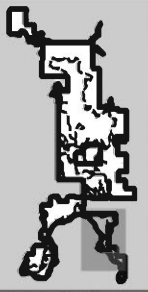

# BRUSHY CREEK STATE RECREATION AREA

## Trail Map - Southeast

- Shelter
- Cemetery Trail, Multi Use
- Day Use Trail, Multi Use
- East River Loop, Multi Use
- Mouth Trail, Multi Use
- Swamp Trail, Multi Use
- West River Loop, Multi Use
- Roads
- Park Boundary



Multi-use Trails: Hiking, Mtn Biking  
X-C Sking, Snowmobile, Equestrian

Trails open to foot traffic only during wet conditions. Call the park office for trail conditions. The Lake Trail is an all-weather rock trail that remains open.

Park Office: 515-543-8298  
Sheriff's Dept: 515-573-1410

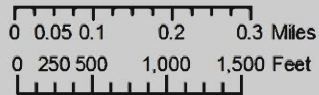

Contour interval 20 feet

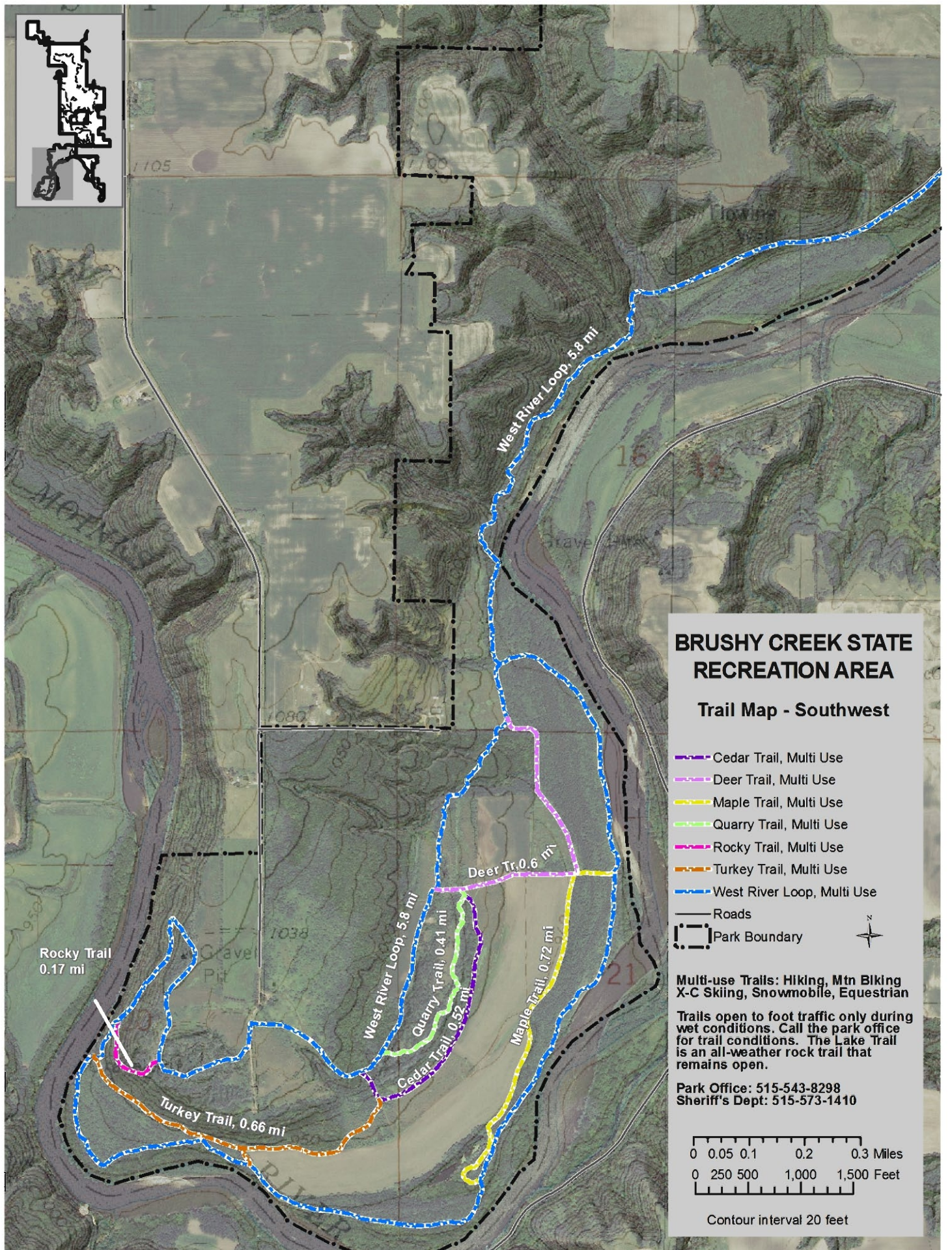

# BRUSHY CREEK STATE RECREATION AREA

## Trail Map - Southwest

- Cedar Trail, Multi Use
- Deer Trail, Multi Use
- Maple Trail, Multi Use
- Quarry Trail, Multi Use
- Rocky Trail, Multi Use
- Turkey Trail, Multi Use
- West River Loop, Multi Use
- Roads
- Park Boundary

Multi-use Trails: HIKING, Mtn BIKING  
X-C Skiing, Snowmobile, Equestrian

Trails open to foot traffic only during wet conditions. Call the park office for trail conditions. The Lake Trail is an all-weather rock trail that remains open.

Park Office: 515-543-8298  
Sheriff's Dept: 515-573-1410

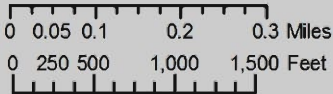

Contour interval 20 feet